

# 1173 Awning Window

## SPECIFICATIONS

### Frame and Sash

All frame and sash profiles are extruded by North Star Windows from virgin PVC powder material. Frames and sash are multi-chamber design for strength and energy efficiency. Frames and sash are fusion welded ensuring a water and airtight seal as well as maximum strength and squareness. Frames are a full 3 ¼" depth.

### Insulated Glass

Double or triple insulating glass with Edgetech silicone foam low conductive S-Class Super Spacer®. Pilkington Energy Advantage™ Low E (hard coat) glass is standard. Cardinal LoE<sup>3</sup>-366® (soft coat) glass is optional as well as Pilkington Activ™ Self-Cleaning glass. Laminated glass is available consisting of 3mm glass, 3/8" airspace and two 3mm glass panes with a .030" clear interior membrane in-between. Heavy inert argon or krypton gas is optional for the air space between the glass panes.

### Glazing

Neoprene setting blocks are placed around glass in sash in diagonal pattern with silicone toe bead sealant to interior glazing cavity to stabilize glass movement. Furnish laid in insulated glass from interior side of sash against flexible fin weather strip extruded to exterior edge of sash. Install architectural profiled interior glazing stops with soft flexible fin weather-strip against interior glass face.

### Triple Weather-Stripping

Two flexible dual durometer bulb type compression gaskets are located around perimeter of window frame to ensure air and water tight seal and maximum energy efficiency. One water repellent pile weather-strip with stiff fin type vapor barrier is located around perimeter of sash increasing energy efficiency and reducing dust and dirt from accumulating around sash cavity.

### Hardware

Truth Maxim hardware has concealed scissor hinges and heavy duty roto gear operator. The roto gear operator will hold the sash at any position. Sash lock pulls weather-stripped sash against dual compression weather-strips on frame. Dual sash locks located on window jamb. All steel components have Truth E-Gard™ coating for superior corrosion protection. Snubber hardware on windows 42" wide and over is applied to the frame and sash at head of window to ensure compression of the bulb weather-strip opposite to sill hardware.

### Hardware Options

Standard Truth Maxim roto gear operator and sash locks are standard in white with contour handle. Truth Encore folding handle with roto gear nesting cover is available in white, faux bronze, brushed antique chrome, satin nickel and oil rubbed bronze finish.

### Screen

North Star Heavy Duty EZ-Screens are roll formed from heavy duty .025" thick aluminum coil flatstock and screened with anti-glare fiberglass cloth. Screen frame has spring loaded corner keys for easy removal and installation of screen. Standard screens are white. Also available are Kolonial Oak and Stainable/Paintable laminated screen frames with mitered corners that include spring loaded corner keys for easy removal and installation.

### Exterior and Interior Finishes

North Star standard vinyl extrusion has a clean, bright, white smooth finish. Seven North Star exterior textured color finishes (ivory, chestnut brown, cocoa, hickory, sandalwood, sable and espresso) and two interior wood grains (Kolonial Oak and Stainable/Paintable Pine) are optional. Exterior color and interior wood grain are applied PVC laminate film with an acrylic overlay for exceptional UV protection. Exterior laminate is 200µm (microns) thick. Special option: espresso interior laminate combined with espresso exterior laminate is available for this window type.

### Grilles

Windows may be enhanced with North Star 5/16" narrow and 5/8" wide flat rectangular or 5/8" wide contoured grilles between the glass panes. 5/16" narrow grilles are available in white, pewter and brass. A combination of white or wood grain interior and colored exterior is optional for 5/8" wide flat grilles. 5/8" wide flat grilles are available in pewter, white or black on all sides. Contoured 3/4" wide grilles are optional in white or white/colored exterior.

### Divided Lites

Classic simulated divided lites (SDL) are also available. SDL grilles are available in 7/8" and 2" widths. Standard SDL comes without airspace grille. Optional 1/4" X 5/16" pewter airspace grilles are available on double glazed units only. SDL grille bars are permanently applied to the interior and exterior glass surface.

### Accessories

North Star offers a variety of vinyl accessories such as nailing fin, brick molds, drywall/wood return, couplers and jamb extensions.

### Standards

North Star windows have been tested by an independent laboratory for air, water, structural and thermal performance requirements.

## 1173 Awning Window Details

HEAD DETAIL

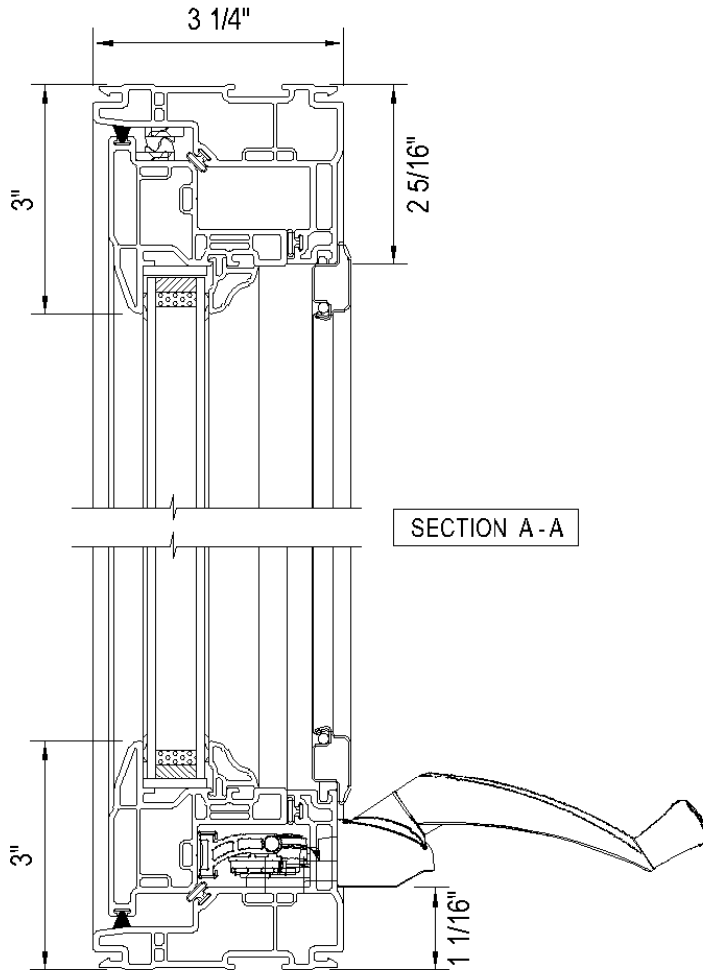

CAN/CSA A440-00

Air: A3

Water: B7

Structural: C4

Screen: S2

Forced Entry: F20

DP Rating: R-PG65-AP

Water Resistance (psf): 690 (14.25)

Air Infiltration/Exfiltration: A3

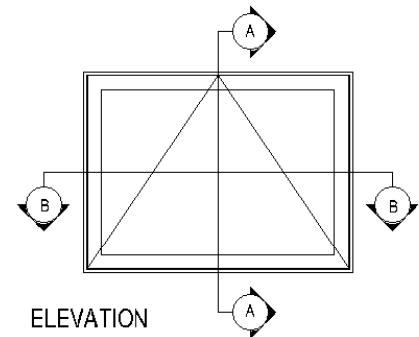

SILL DETAIL

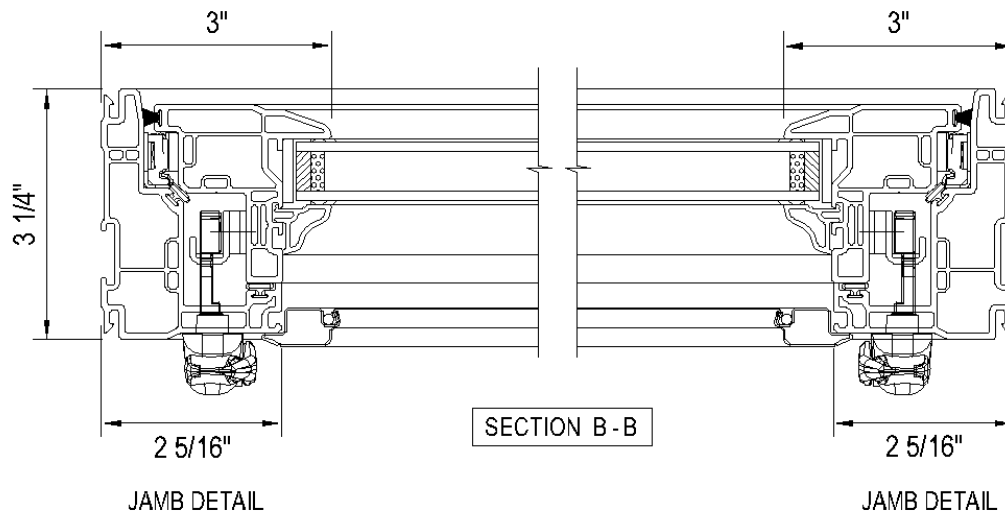

**1173 Awning Window - Mullion Details**

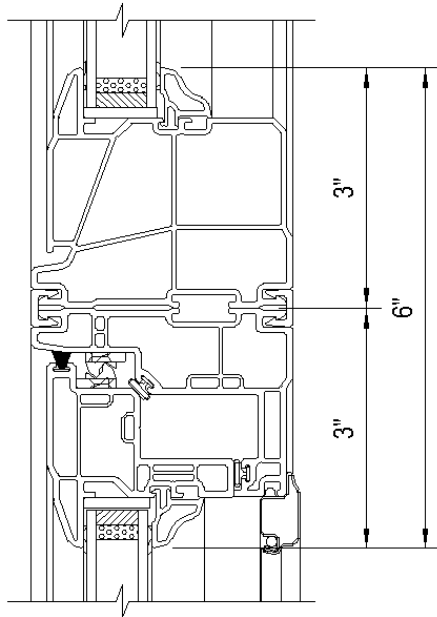

**A - PICTURE OVER AWNING  
MULLION DETAIL**

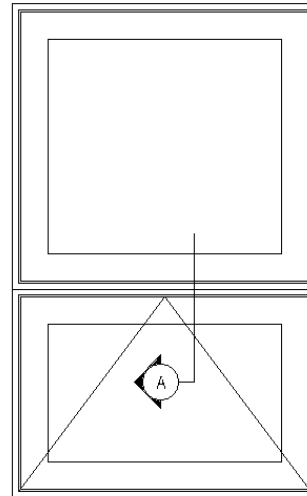

**ELEVATION  
EXTERIOR VIEW**

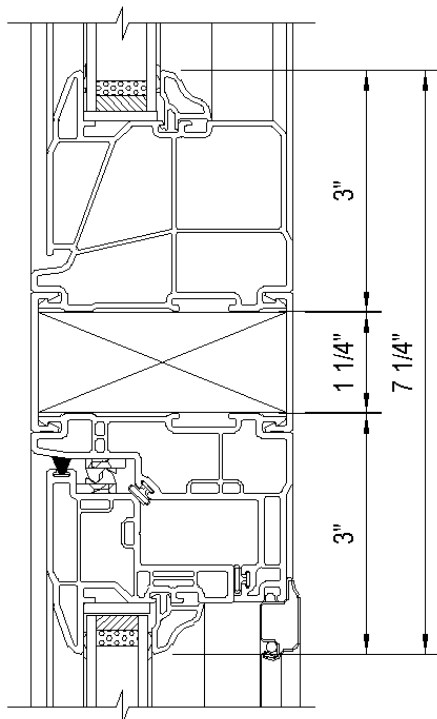

**B - PICTURE OVER AWNING  
MULLION REINFORCEMENT DETAIL**

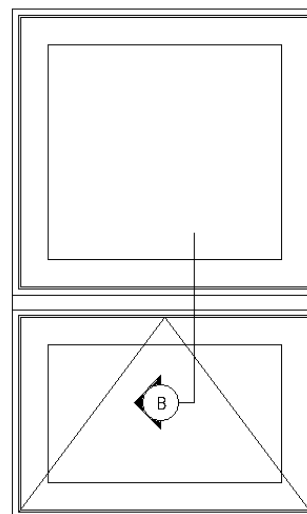

**ELEVATION  
EXTERIOR VIEW**

**1173 Awning Window - Mullion Details**

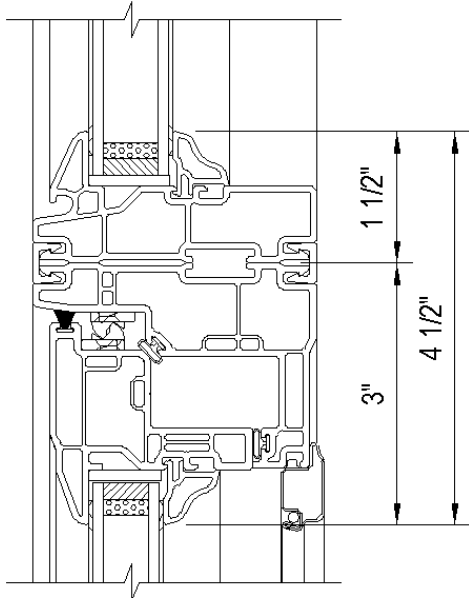

**A - FIXED OVER AWNING  
MULLION DETAIL**

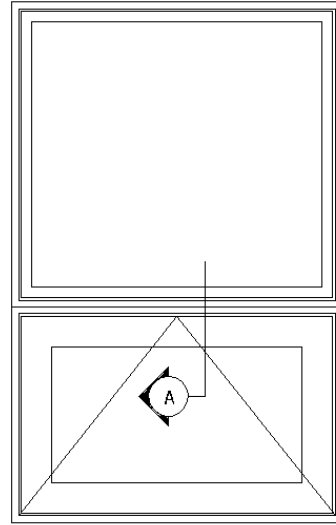

**ELEVATION  
EXTERIOR VIEW**

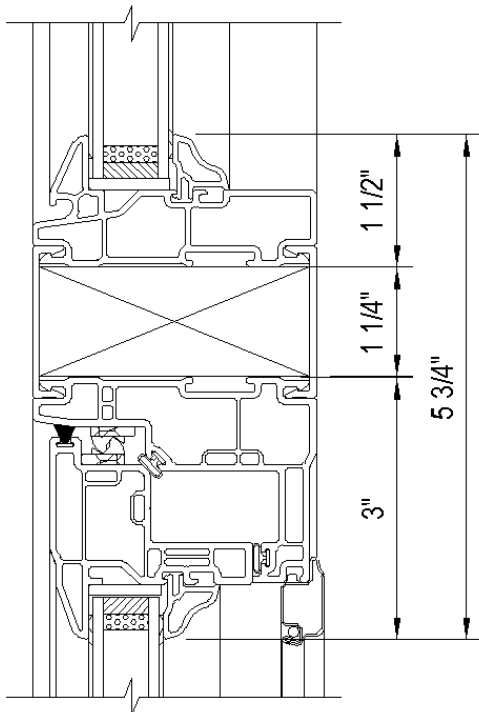

**B - FIXED OVER AWNING  
MULLION REINFORCEMENT DETAIL**

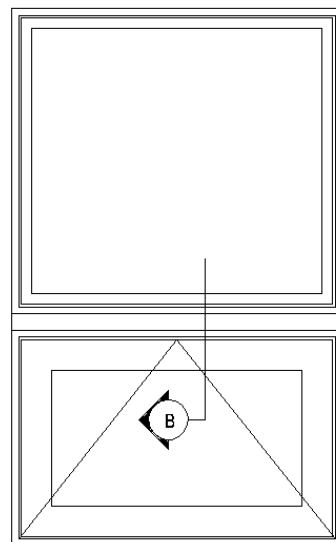

**ELEVATION  
EXTERIOR VIEW**

**1173 Awning Window - Mullion Details**

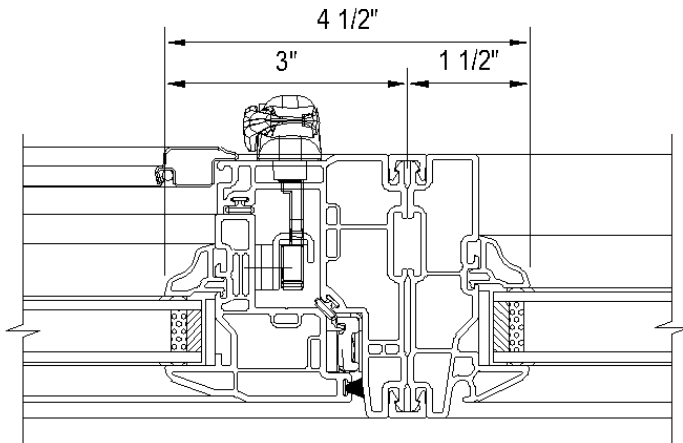

A - AWNING/FIXED  
MULLION DETAIL

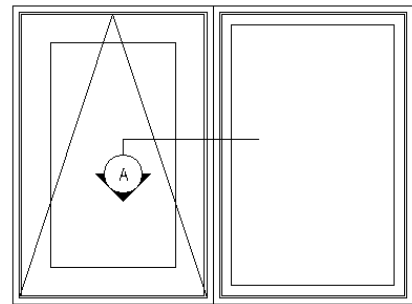

ELEVATION  
EXTERIOR VIEW

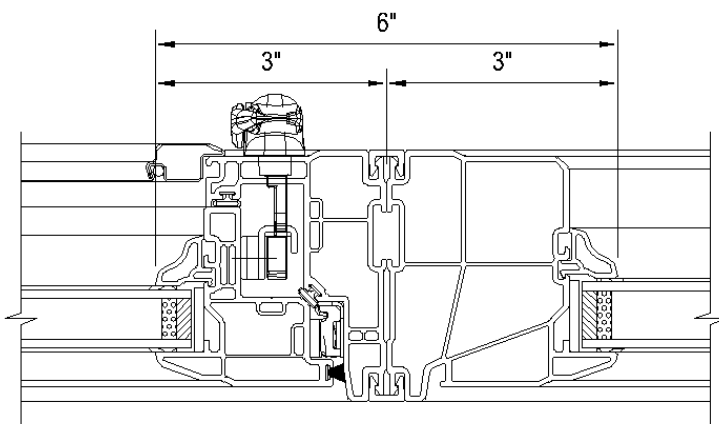

B - AWNING/PICTURE  
MULLION DETAIL

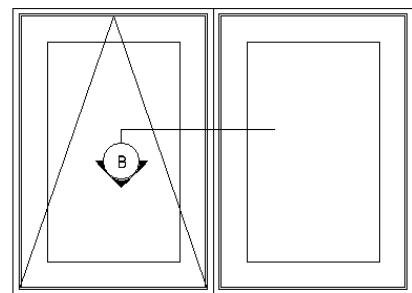

ELEVATION  
EXTERIOR VIEW