

1071 Picture Window (No Sash)

SPECIFICATIONS

Frame

Combined frame and stop profiles are extruded by North Star Windows from virgin PVC powder material. Frames are multi-chamber design for strength and energy efficiency. Frame is fusion welded ensuring a water and airtight seal as well as maximum strength and squareness. Frames are a full 3 ¼" depth.

Insulated Glass

Double or triple insulating glass with Edgetech silicone foam low conductive S-Class Super Spacer®. Pilkington Energy Advantage™ Low E (hard coat) glass is standard. Cardinal LoE³-366® (soft coat) glass is optional as well as Pilkington Activ™ Self-Cleaning glass. Laminated glass is available consisting of 3mm glass, 3/8" airspace and two 3mm glass panes with a .030" clear interior membrane in-between. Heavy inert argon or krypton gas is optional for the air space between the glass panes.

Glazing

Insert neoprene setting blocks around perimeter of frame with application of silicone toe bead sealant to interior glazing cavity to stabilize glass movement. Furnish laid in insulated glass from interior side of frame against flexible vinyl fin weather-strip co-extruded to exterior edge of frame. Install architectural profiled interior glazing stops with flexible co-extruded vinyl fin weather-strip against interior glass face.

Weather-Stripping

Profiled exterior frame edge and profiled interior glass stop have co-extruded flexible vinyl fin weather-strip which seals against exterior and interior glass faces.

Exterior and Interior Finishes

North Star standard vinyl extrusion has a clean, bright, white smooth finish. Seven North Star exterior textured color finishes (ivory, chestnut brown, cocoa, hickory, sandalwood, sable and espresso) and two interior wood grains (Kolonial Oak and Stainable/Paintable Pine) are optional. Exterior color and interior wood grain are applied PVC laminate film with an acrylic overlay for exceptional UV protection. Exterior laminate is 200µm (microns) thick. Special option: espresso interior laminate combined with espresso exterior laminate is available for this window type.

Grilles

Windows may be enhanced with North Star 5/16" narrow and 5/8" wide flat rectangular or 5/8" wide contoured grilles between the glass panes. 5/16" narrow grilles are available in white, pewter and brass. A combination of white or wood grain interior and colored exterior is optional for 5/8" wide flat grilles. 5/8" wide flat grilles are available in pewter, white or black on all sides. Contoured 3/4" wide grilles are optional in white or white/colored exterior.

Divided Lites

Classic simulated divided lites (SDL) are also available. SDL grilles are available in 7/8" and 2" widths. Standard SDL comes without airspace grille. Optional 1/4" X 5/16" pewter airspace grilles are available on double glazed units only. SDL grille bars are permanently applied to the interior and exterior glass surface.

Accessories

North Star offers a variety of vinyl accessories such as nailing fin, brick molds, drywall/wood return, couplers and jamb extensions.

Standards

North Star windows have been tested by an independent laboratory for air, water, structural and thermal performance requirements. #

1071 Picture Window (No Sash) Details

HEAD DETAIL

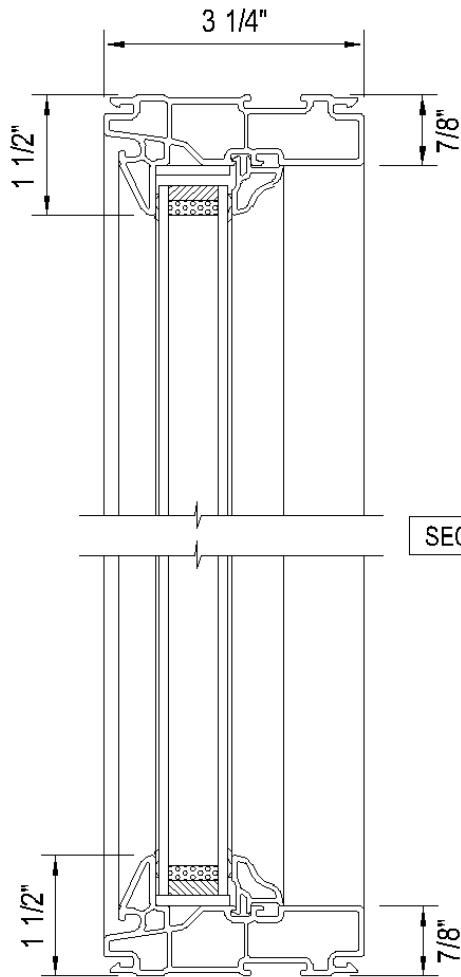

CAN/CSA A440-00

Air: (A) Fixed Rating

Water: B7

Structural: C5

Forced Entry: N/A

DP Rating: CW-PG70-FW

Water Resistance (psf): 730 (15.0)

Air Infiltration/Exfiltration: Fixed

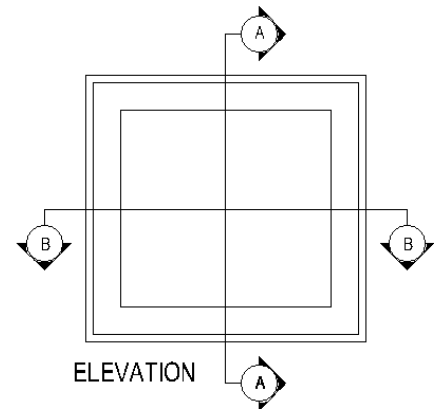

SILL DETAIL

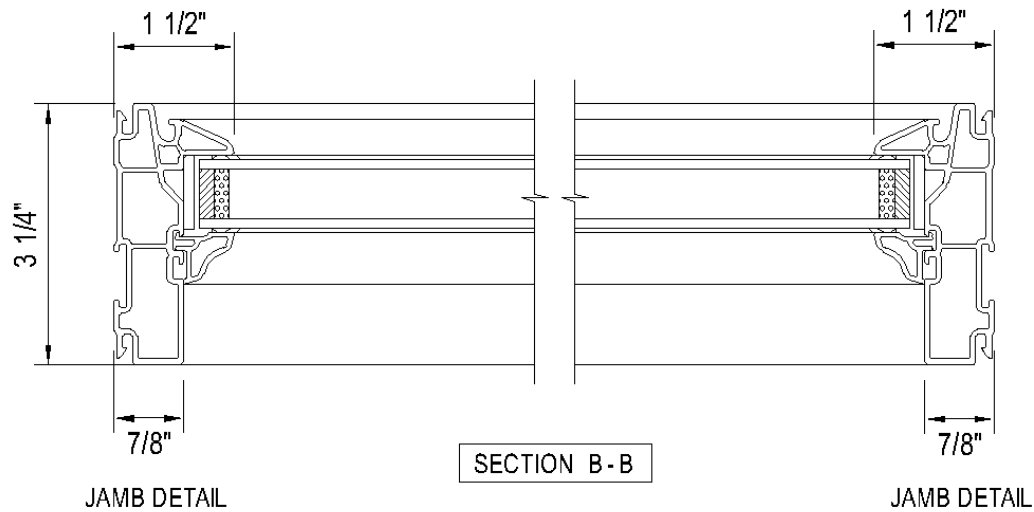

#

1071 Architectural Shaped Window

SPECIFICATIONS

Frame

Combined frame and stop profiles are extruded by North Star Windows from virgin PVC powder material. Frames are multi-chamber design for strength and energy efficiency. Frame is fusion welded ensuring a water and airtight seal as well as maximum strength and squareness. Frames are a full 3 ¼" depth.

Insulated Glass

Double or triple insulating glass with Edgetech silicone foam low conductive S-Class Super Spacer®. Pilkington Energy Advantage™ Low E (hard coat) glass is standard. Cardinal LoE³-366® (soft coat) glass is optional as well as Pilkington Activ™ Self-Cleaning glass. Laminated glass is available consisting of 3mm glass, 3/8" airspace and two 3mm glass panes with a .030" clear interior membrane in-between. Heavy inert argon or krypton gas is optional for the air space between the glass panes.

Glazing

Insert neoprene setting blocks around perimeter of frame with application of silicone toe bead sealant to interior glazing cavity to stabilize glass movement. Furnish laid in insulated glass from interior side of frame against flexible vinyl fin weather-strip co-extruded to exterior edge of frame. Install architectural profiled interior glazing stops with flexible co-extruded vinyl fin weather-strip against interior glass face.

Weather-Stripping

Profiled exterior frame edge and profiled interior glass stop have co-extruded flexible vinyl fin weather-strip which seals against exterior and interior glass faces.

Exterior and Interior Finishes

North Star standard vinyl extrusion has a clean, bright, white smooth finish. Seven North Star exterior textured color finishes (ivory, chestnut brown, cocoa, hickory, sandalwood, sable and espresso) and two interior wood grains (Kolonial Oak and Stainable/Paintable Pine) are optional. Exterior color and interior wood grain are applied PVC laminate film with an acrylic overlay for exceptional UV protection. Exterior laminate is 200µm (microns) thick. Special option: espresso interior laminate combined with espresso exterior laminate is available for this window type.

Grilles

Windows may be enhanced with North Star 5/16" narrow and 5/8" wide flat rectangular or 5/8" wide contoured grilles between the glass panes. 5/16" narrow grilles are available in white, pewter and brass. A combination of white or wood grain interior and colored exterior is optional for 5/8" wide flat grilles. 5/8" wide flat grilles are available in pewter, white or black on all sides. Contoured 3/4" wide grilles are optional in white or white/colored exterior.

Divided Lites

Classic simulated divided lites (SDL) are also available. SDL grilles are available in 7/8" and 2" widths. Standard SDL comes without airspace grille. Optional 1/4" X 5/16" pewter airspace grilles are available on double glazed units only. SDL grille bars are permanently applied to the interior and exterior glass surface.

Accessories

North Star offers a variety of vinyl accessories such as nailing fin, brick molds, drywall/wood return, couplers and jamb extensions.

Standards

North Star windows have been tested by an independent laboratory for air, water, structural and thermal performance requirements.

Non-Bent Geometric Shapes

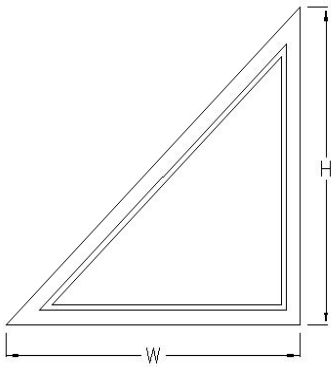

TRIANGLE
MODEL #1030

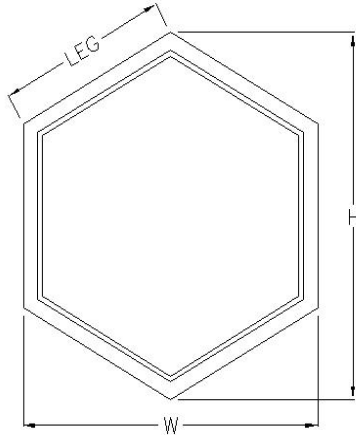

HEXAGON
MODEL #1031

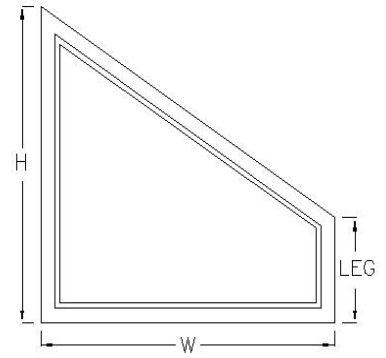

TRAPEZOID
MODEL #1032

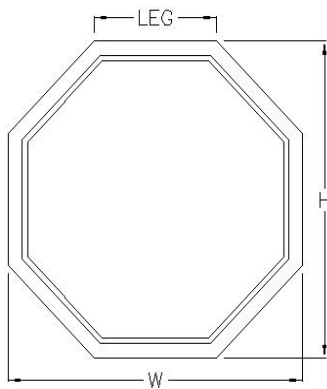

OCTAGON
MODEL #1033

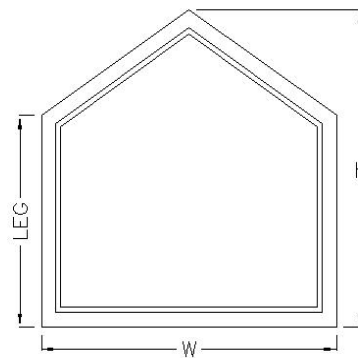

PENTAGON
MODEL #1034

Bent Geometric Shapes

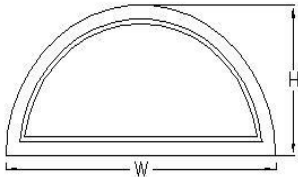

HALF ARCH
MODEL #1023

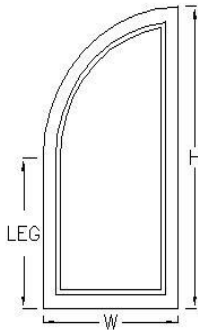

EXTENDED QUARTER ARCH
MODEL #1028B

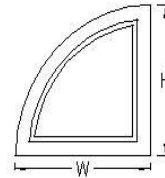

QUARTER ARCH
MODEL #1027

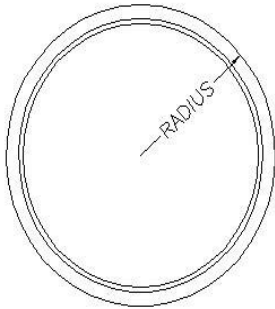

FULL CIRCLE
MODEL #1024

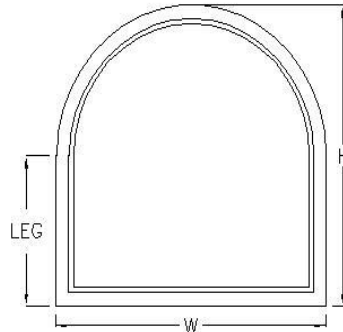

EXTENDED ARCH
MODEL #1028

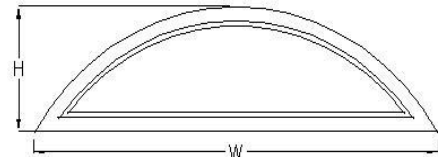

CORD/EYEBROW
MODEL #1025

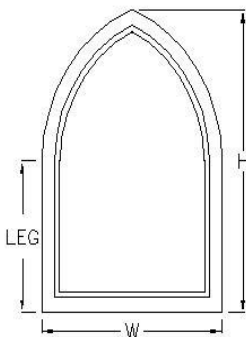

CATHEDRAL
MODEL #1029

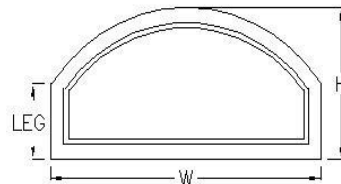

ELIPSE TOP
MODEL #1026

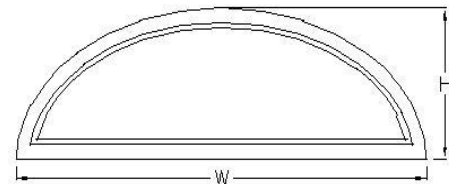

TRUE ELIPSE
MODEL #1037

1071 Picture Window (No Sash) - Mullion Details

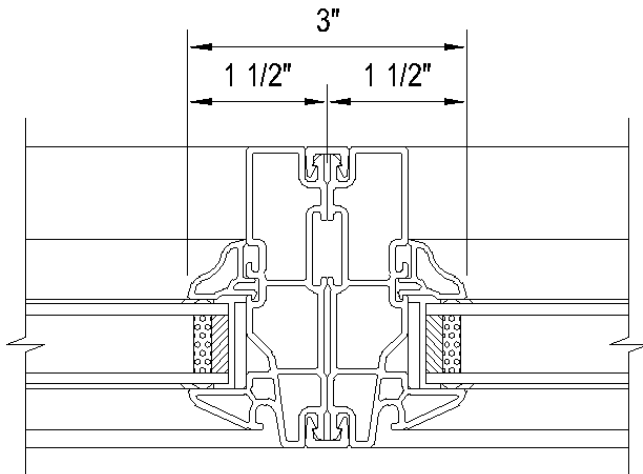

A - FIXED/FIXED
MULLION DETAIL

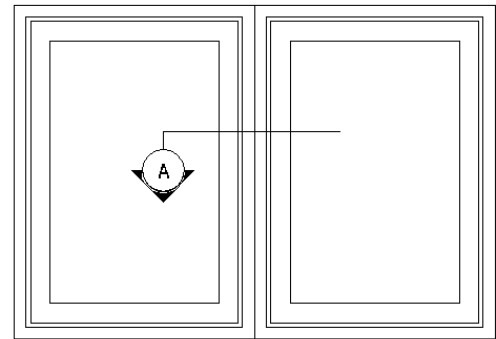

ELEVATION
EXTERIOR VIEW

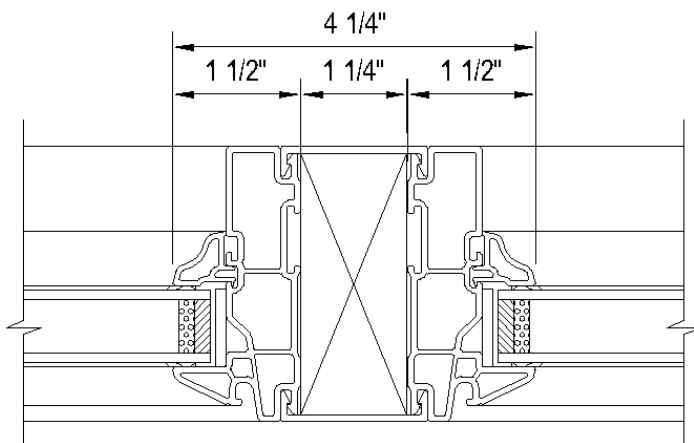

B - FIXED/FIXED
MULLION REINFORCEMENT DETAIL

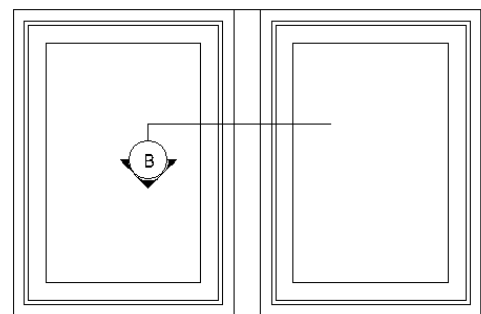

ELEVATION
EXTERIOR VIEW