

5372 Single Slider Liftout Window

SPECIFICATIONS

Note: Single Slider 5372 has left side operating and right side fixed.

Frame and Sash

All frame and sash profiles are extruded from virgin PVC powder material. Frames and sash are multi-chamber design for strength and energy efficiency. Frames complete with recessed drain covers with reticulated foam to keep insects out. Frames and sash are fusion welded ensuring a water and airtight seal as well as maximum strength and squareness. Frames incorporate hidden exterior accessory groove and an integrated wood/drywall return on interior. Frames are a full 5 ¼" depth.

Insulated Glass

Double or triple insulating glass with Edgetech silicone foam low conductive S-Class Super Spacer®. Pilkington Energy Advantage™ Low E (hard coat) glass is standard. Cardinal LoE³-366® (soft coat) glass is optional as well as Pilkington Activ™ Self-Cleaning glass. Laminated glass is available consisting of 3mm glass, 1/2" airspace and two 3mm glass panes with a .030" clear interior membrane in-between. Heavy inert argon or krypton gas is optional for the air space between the glass panes.

Glazing

Insert neoprene setting blocks around perimeter of sash with application of silicone toe bead sealant to interior glazing cavity to stabilize glass movement. Furnish laid in insulated glass from interior side of sash against flexible vinyl fin weather-strip co-extruded to exterior edge of sash. Install interior glazing stops with flexible co-extruded vinyl fin weather-strip against interior glass face.

Multiple Weather-Stripping

Six water repellant pile weather-strips with stiff fin type vapor barriers are located around perimeter of each operable window sash to ensure air and water tight seal and maximum energy efficiency. Two interior side water repellant pile weather-strips with stiff fin type vapor barrier are located on the inside of window frame at sill and jamb location; as well as a third weather strip on fixed sash checkrail for additional protection against air and water penetration.

Hardware

Two die-cast self-latching cam locks and keeper are assembled onto each operable sash for weatherability and security. Windows less than 30" in height require one cam lock and keeper. Sash release latches are secured to sash to allow tilt in and lift out of operating sash for ease of cleaning. Tandem brass rollers located on bottom of sash allow for smooth effortless opening and closing of sash. Full length sash pull handles are extruded into the interior glazing stop profile. Standard profile color is white.

Hardware Options

Note: Limit sash opening features are available. Consult your North Star Sales Consultant for details.

Screen

North Star screens are roll formed from heavy .021" thick aluminum coil flatstock and screened with anti-glare fiberglass cloth. Screen frame has nylon injection molded corner key with pull tab. Screen frame is available in white.

Exterior and Interior Finishes

North Star standard vinyl extrusion has a clean, bright, white smooth finish on the interior and exterior.

Grilles

Windows may be enhanced with North Star 5/16" narrow and 5/8" wide flat rectangular or 5/8" wide contoured grilles between the glass panes. 5/16" narrow grilles are available in white, pewter and brass. Contoured 5/8" wide grilles are available in white only. 5/8" wide flat grilles are also available in pewter.

Divided Lites

Classic simulated divided lites (SDL) are also available. SDL grilles are available in 7/8" and 2" widths. Standard SDL comes without airspace grille. Optional 1/4" X 5/16" pewter airspace grilles are available on double glazed units only. SDL grille bars are permanently applied to the interior and exterior glass surface.

Accessories

North Star offers a variety of vinyl accessories such as folding nailing fin, brickmolds, couplers and jamb extensions.

Standards

North Star windows have been tested by an independent laboratory for air, water, structural and thermal performance requirements.

Egress

Consult local building codes to verify that the window ordered meets or exceeds egress requirements for your area. Special egress hardware is available for single slider liftout windows that enable narrow sizes to meet egress codes.

5372 Single Slider Liftout Window Details

HEAD DETAIL

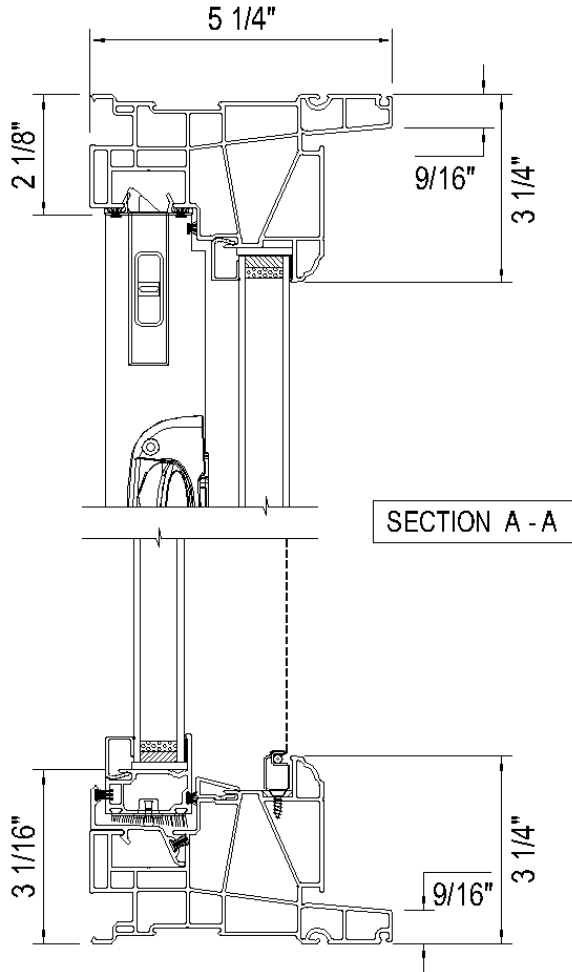

SECTION A - A

CAN/CSA A440-00	
Air: A3/Fixed	
Water: B4	
Structural: C4	
Screen: S1	
Forced Entry: F20	
<hr/>	
DP Rating: R-PG60-HS	
Water Resistance (psf): 620 (12.75)	
Air Infiltration/Exfiltration: A3	

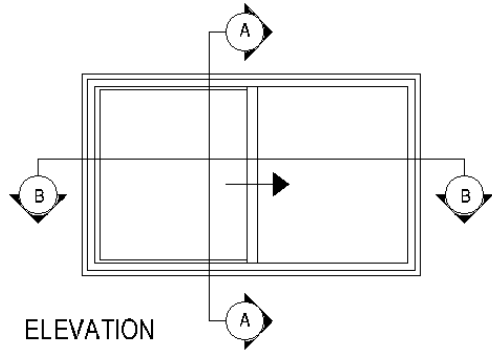

ELEVATION

SILL DETAIL

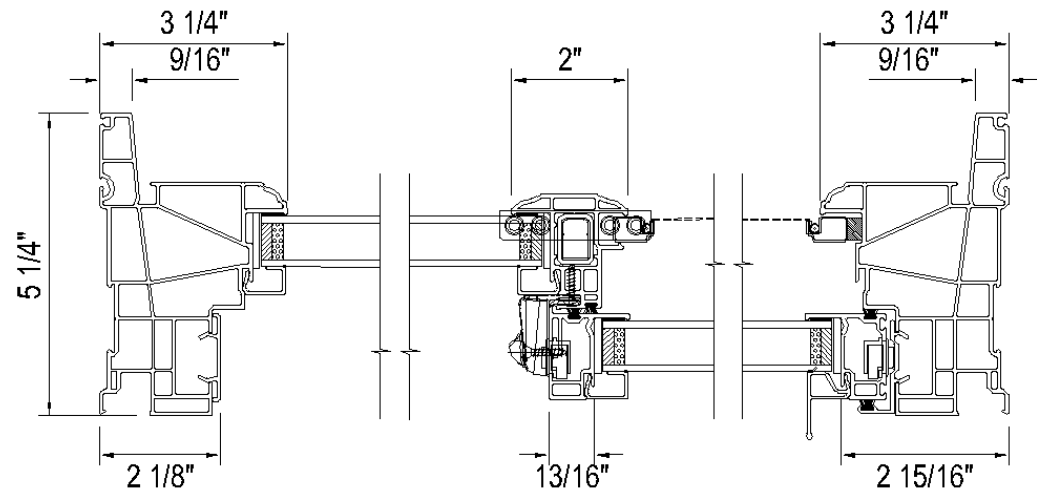

JAMB DETAIL

SECTION B - B

JAMB DETAIL