

1271 Double Hung Tilt Window

SPECIFICATIONS

Frame and Sash

All frame and sash profiles are extruded by North Star Windows from virgin PVC powder material. Frames and sash are multi-chamber design for strength and energy efficiency. Frames complete with recessed drain covers with reticulated foam to keep insects out. Frames and sash are fusion welded ensuring a water and airtight seal as well as maximum strength and squareness. Frames are a full 3 1/4" depth.

Insulated Glass

Double or triple insulating glass with Edgetech silicone foam low conductive S-Class Super Spacer®. Pilkington Energy Advantage™ Low E (hard coat) glass is standard. Cardinal LoE³-366® (soft coat) glass is optional as well as Pilkington Activ™ Self-Cleaning glass. Laminated glass is available consisting of 3mm glass, 3/8" airspace and two 3mm glass panes with a .030" clear interior membrane in-between. Heavy inert argon or krypton gas is optional for the air space between the glass panes.

Glazing

Insert neoprene setting blocks around perimeter of sash with application of silicone toe bead sealant to interior glazing cavity to stabilize glass movement. Furnish laid in insulated glass from interior side of sash against flexible vinyl fin weather-strip co-extruded to exterior edge of sash. Install interior glazing stops with flexible co-extruded vinyl fin weather-strip against interior glass face.

Multiple Weather-Stripping

Water repellant pile weather-strips with stiff fin type vapor barrier are located around perimeter of each operable window sash to ensure air and water tight seal and maximum energy efficiency. Two additional pile weather-strip with stiff fin type vapor barrier are located on the inside of window frame at sill and jamb location for additional protection against air and water penetration.

Hardware

Two die-cast cam locks and keeper are assembled onto each operable sash for weatherability and security. Windows less than 27 1/2" in width require one cam lock and keeper. Each sash is operated with two spiral balance hardware. True recessed finger latches release both top and bottom sash to allow sash to tilt in for ease of cleaning. Full length sash pull handles are extruded into the interior glazing stop profile. Standard color is white.

Hardware Options

Self-latching locks and keepers are available as an option. Faux finish color locks, keepers and tilt latches are standard features when Kolonial Oak or Stainable/Paintable pine laminated interior finish is ordered.

Note: Limit sash opening features are available. Consult your North Star Sales Consultant for details.

Screen

North Star screens are roll formed from heavy .021" thick aluminum coil flatstock and screened with anti-glare fiberglass cloth. Screen frame has nylon injection molded corner key with pull tab. Screen frame is available in white or North Star's seven exterior colors. Double hung is standard with full screen.

Exterior and Interior Finishes

North Star standard vinyl extrusion has a clean, bright, white smooth finish. Seven North Star exterior textured color finishes (ivory, chestnut brown, cocoa, hickory, sandalwood, sable and espresso) and two interior wood grains (Kolonial Oak and Stainable/Paintable Pine) are optional. Exterior color and interior wood grain are applied PVC laminate film with an acrylic overlay for exceptional UV protection. Exterior laminate is 200µm (microns) thick.

Grilles

Windows may be enhanced with North Star 5/16" narrow and 5/8" wide flat rectangular or 5/8" wide contoured grilles between the glass panes. 5/16" narrow grilles are available in white, pewter and brass. A combination of white or wood grain interior and colored exterior is optional for 5/8" wide flat grilles. 5/8" wide flat grilles are available in pewter, white or black on all sides. Contoured 3/4" wide grilles are optional in white or white/colored exterior.

Divided Lites

Classic simulated divided lites (SDL) are also available. SDL grilles are available in 7/8" and 2" widths. Standard SDL comes without airspace grille. Optional 1/4" X 5/16" pewter airspace grilles are available on double glazed units only. SDL grille bars are permanently applied to the interior and exterior glass surface.

Accessories

North Star offers a variety of vinyl accessories such as nailing fin, brick molds, drywall/wood return, couplers and jamb extensions.

Standards

North Star windows have been tested by an independent laboratory for air, water, structural and thermal performance requirements.

Egress

Consult local building codes to verify that the window ordered meets or exceeds egress requirements for your area. Special egress hardware is available for double hung tilt windows that enable narrow sizes to meet egress codes.

1271 Double Hung Tilt Window Details

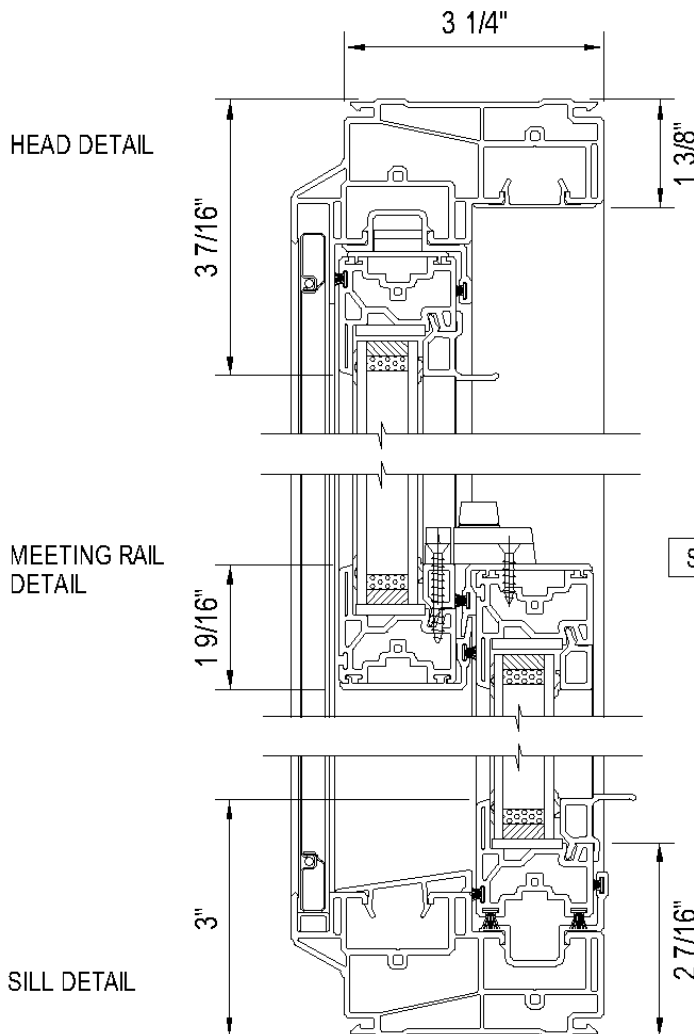

CAN/CSA A440-00

Air: A2

Water: B6

Structural: C5

Screen: S1

Forced Entry: F10

DP Rating: R-PG40-H

Water Resistance (psf): 730 (15.0)

Air Infiltration/Exfiltration: A2

SECTION A-A

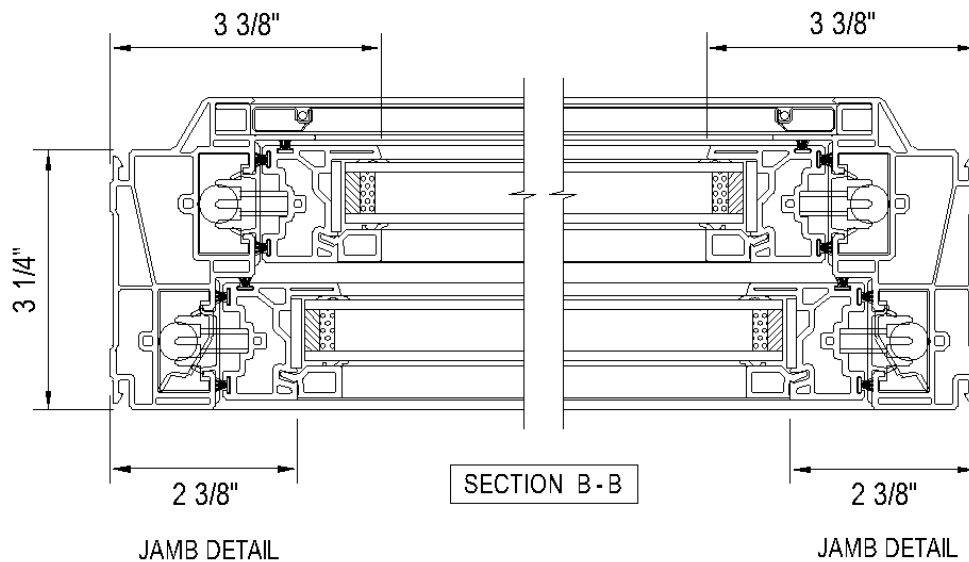
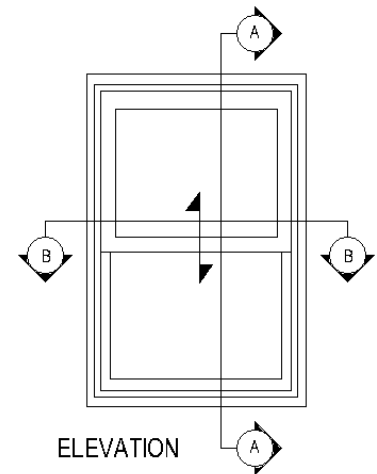

1271 Double Hung Tilt Window - Mullion Details

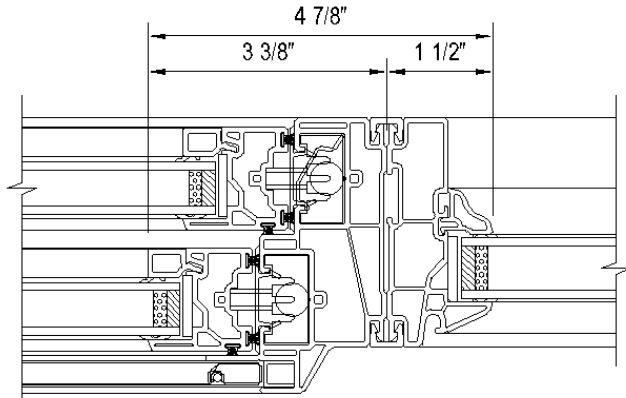

A - DOUBLE HUNG TILT/FIXED
MULLION DETAIL

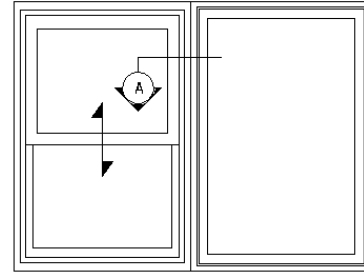

ELEVATION
EXTERIOR VIEW

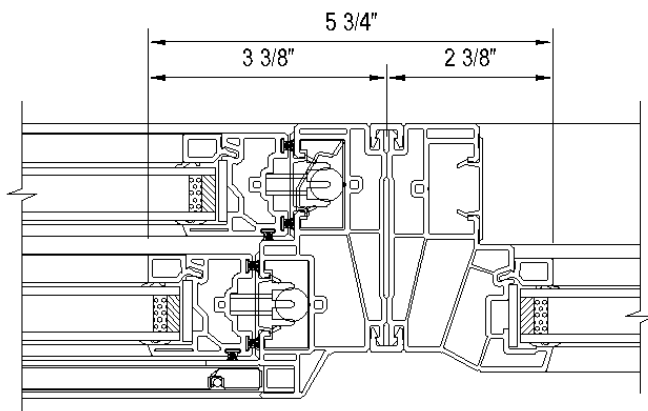

B - DOUBLE HUNG TILT/PICTURE (SINGLES FRAME)
MULLION DETAIL

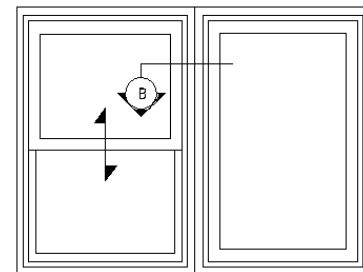

ELEVATION
EXTERIOR VIEW

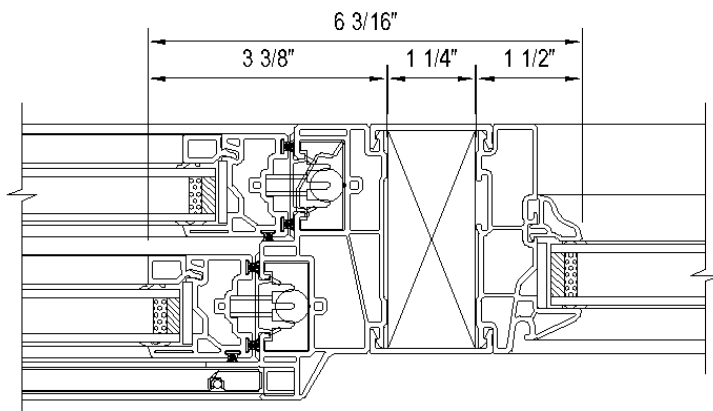

C - DOUBLE HUNG TILT/FIXED
MULLION REINFORCEMENT DETAIL

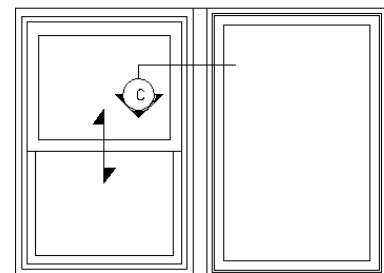

ELEVATION
EXTERIOR VIEW